

HC-33 DEMAGNETIZER

Thank you for purchasing the HOZAN HC-33 DEMAGNETIZER. With proper care and handling, this fine instrument will provide years of trouble-free operation. Please read this entire instruction manual carefully before attempting to place this instrument in service. Please keep this instruction manual available for reference.

Identification of parts

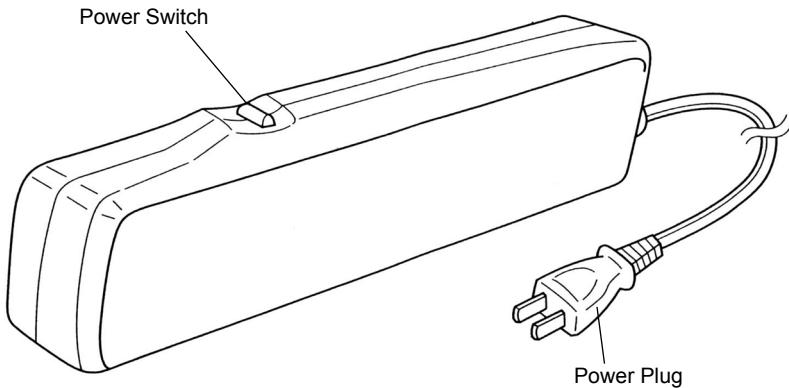

●HC-33 is for 100 V.
Do not use by any other voltages.

Specifications

Rating	100 Vac	
Frequency	50 Hz	60 Hz
Power consumption	12 W (at steady state)	
Dimensions	34(W)X59(H)X216(D) mm	
Weight	930 g	
Max. magnetic flux density	68mT(680Gs)	56mT(560Gs)
Steady-state current	1.0A	

Warning and caution symbols

These symbols are used throughout the instruction manual to alert the user to potential safety hazards as follows :

 **Warning** ... Notice when incorrect handling could cause the user's death or serious injury.

 **Caution** ... Notice when incorrect handling could cause injury to the user or material damage.

Even if the instructions do not have  **Caution** mark, there are some possibilities for a serious situation. Follow the instructions.

Precautions

Warning

1. Do not use by any other voltages than 100 Vac. This could cause a malfunction or fire.
2. Do not disassemble or modify the tool yourself. Otherwise, this could cause a malfunction.
3. Do not pull the power cord strongly, bend it or tread on it. Also, do not place objects with sharp corners on top of the cord. Otherwise, the cord breaks, and short-circuits or fire result.
4. This demagnetizer generates a strong alternating field. Do not point at a person. If the operator is using a pacemaker for his/her heart, this could cause a disorder to the pacemaker. When a disorder is felt, immediately stop using this demagnetizer and consult a doctor.

Caution

1. If feel that this device has excessive heat, use again after cool the heat enough. Using without doing any care could cause dropping of magnetism. In that case, use after cooled down or in the way of "for other objects" on page 4.
2. Be sure to plug off when this device is not in use. The unit heats up more than ambient temperature when plugged in even the power switch is off, but this is not malfunction.
3. Do not drop this device or subject it to any shocks.
4. Do not use this device to demagnetize the magnetized heads of tape recorders, which adversely demagnetize the erase heads.
5. If demagnetizing the inside of video recorder, keep the tool away from parts such as purity and convergence magnets. If close to such parts, malfunctioning of the video recorder results.
6. Keep this device clear of objects such as wristwatches, magnetic tapes and magnetic disks which could be adversely affected by magnetic fields while using.

Distance and magnetic flux density, thermal controller

The following data shows the relationships between distance and magnetic flux density.

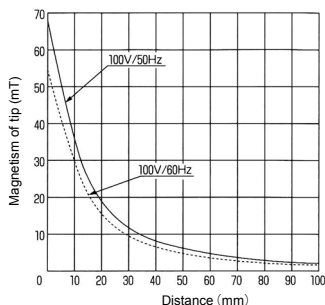

Measurement apparatus :

Gauss meter : GM-4000 manufactured by Electromagnetic Industries Co., Ltd.

Sensor probe : T22078 manufactured by Electromagnetic Industries Co., Ltd.

Regarding thermal controller

This has an automatic thermal controller which limits the power and magnetism will fall to 20-30 mT when the coil becomes to excessively high temperature. Cool it spontaneously down 15-20 minutes so that magnetism recovers the magnetic flux density before.

Principle of demagnetizing

Metals, even not magnetized, possess both the N and S polarities which are in a jumble and stabilized repelling each other. N and S poles in a magnetic material* stand in line under influence of external force. A magnetization is a phenomenon that polarities appear by N and S are standing in line.

This demagnetizer recovers standing-in-line polarities to the stable condition as before by reducing the alternating field.

magnetic material*...substance which is influenced from magnetism

Operation

1 Plug in the power plug to the wall outlet.

2 ● For cathode ray tube

Bring the tip of the HC-33 close to the area where color distortion was occurred on the cathode ray tube. Once push and release the power switch. The power damping function will work and off the power in a second.

Repeat the operation or orient the HC-33 parallel with the tube face.

⚠ Caution

If your PC monitor is by aperture-mask system, after finishing this procedure, sometimes vertical lines appear on the screen by distortion on aperture-musk itself receiving repercussion of the demagnetizer, but this is not malfunction. In case of this, softly hit the side of the monitor set to recover.



● For other objects

Bring the tip of the HC-33 close to the magnetized object. Once push and release the power switch.

It can not be demagnetized enough when used against a tool or a little part. In case of this, close the HC-33 and the object as near as possible, then while pushing the power switch, gradually pull the HC-33 away from the object approximately 30cm, and release the switch.

HOZAN TOOL INDUSTRIAL CO.,LTD.

1-2-12 Saiwaicho, Naniwa-ku, Osaka 556-0021, Japan

<https://www.hozan.co.jp/E/> E-mail : th@hozan.co.jp