

## K-21 DESK DRILL PRESS

Thank you for purchasing the HOZAN K-21 DESK DRILL PRESS. With proper care and handling, this fine instrument will provide years of trouble-free operation. Please read this entire instruction manual carefully before attempting to place this instrument in service. Please keep this instruction manual available for reference.

### Identification of parts and contents

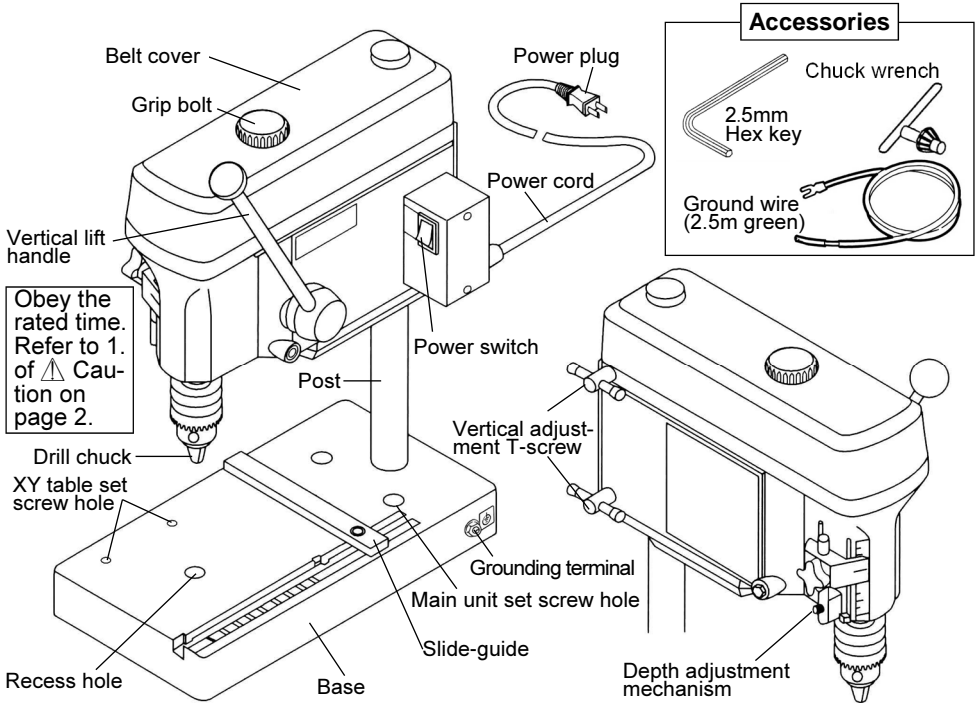

Drills are not provided. Attach an appropriate drill selected referring to Options on page 8.

### Specifications

Main shaft revolution speed	2100/4500/6200rpm (by changing over the belt)	Rating	100Vac 50/60Hz
Drilling performance	Ferrous and non-ferrous metal:6.0mm $\phi$	Power consumption	80W
Main shaft axial play	0.04mm(chuck not installed)	Rated usage time	15minutes
Chuck clamping capacity	0.8-6.0mm $\phi$	Dimensions	120(W) $\times$ 350(H) $\times$ 225(D)mm
		weight	4kg

## Warning and caution symbols

These symbols are used throughout the instruction manual to alert the user to potential safety hazards as follows :

 **Warning** ... Notice when incorrect handling could cause the user's death or serious injury.

 **Caution** ... Notice when incorrect handling could cause injury to the user or material damage.

Even if the instructions do not have  **Caution** mark, there are some possibilities for a

## Precautions

### **Warning**

1. Use only with the line voltage specified on the rating plate. Use of voltage higher rated could cause a fire or malfunction.
2. Do not use the K-21 in place where flammable liquids or gasses are present.
3. Take care to avoid electric shocks.  
Do not use the K-21 in the rain or in place where are extremely damp or wet. While operating, do not make physical contact with any grounded electric appliances.  
Always be sure to ground. Otherwise, this could cause a shock.
4. Do not run the K-21 under excessive loads. Otherwise, the motor may become damaged due to overheating.
5. Do not bring your hands, eyes or face close to the drill bit while operating.
6. Wear neat and proper clothes when using the K-21.  
Loose-fitting closes, ties and long hair could get caught in the moving parts. Do not wear gloves to prevent getting caught.
7. Wear safety glasses while operating. Cutting dust could injure your eyes. Wear a dust-proof mask if necessary.
8. Check the power cord, motor, moving parts, ON/OFF switch and other parts of the K-21 for damage, and check that the drill operates normally. If a problem is found, ask your HOZAN dealer to carry out any necessary repairs.

### **Caution**

1. Do not operate continuously for longer than the rated time.  
[The rated time of K-21 is within 15 minutes.]  
Please take an interval of the minutes equivalent to the operated minutes. A short rest means just a continuous operation.
2. Secure the workpiece firmly. Use a clamp to hold the workpiece if necessary.
3. Always maintain a comfortable posture when using the drill.
4. Turn off the ON/OFF switch and disconnect the power cord at the following times:  
When not in service or when repairing it. When replacing parts.
5. Always follow the instructions given in this manual when installing and replacing the drill bits. If the bits are not installed properly, the bits fall out and it causes an injury.
6. The base is die-cast, so if you hit or drop solid objects on the base, it may cause cracks and dents.
7. The K-21 is not waterproof so do not use water or a wet cloth to clean or wipe the drill.

## Precautions

### ⚠ Caution

8. Store the K-21 in an appropriate place. Do not leave the K-21 for a long time in a place where it is exposed to shock or vibration, in the direct rays of the sun or in a high temperature and/or humidity environment.

## Preparation

- 1 Use commercially-available wood screws to securely attach the base to a work bench. Choose set screws less than 6mm  $\phi$ .

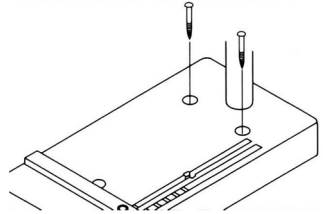

- 2 Attach the vertical lift handle to the main unit. Thread in clockwise.

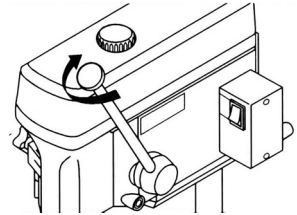

- 3 Adjust the height of the main unit in accordance with the thickness of the workpiece. Loosen the T-screw at the back and move the main unit up or down for the appropriate height. Once the height is determined, securely tighten the T-screw.

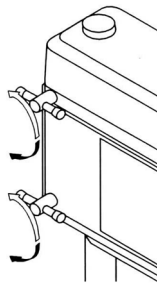

### ⚠ Caution

You can see the available maximum height by removing the belt cover that is the top of the post slightly coming out as shown in the illustration.

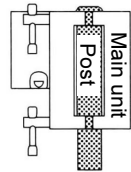

- 4 Install the drill bit. Hold the drill chuck with your hand, and then insert the chuck wrench into the hole at the side of the chuck and turn the wrench to loosen the chuck. Insert the drill bit into the end, and then turn the chuck wrench to securely tighten the drill bit. Be sure to remove the chuck wrench after use.

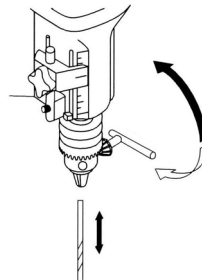

Fully lower the vertical lift handle gradually to be sure that the drill bit enters into the center of the recess hole and does not touch everything.

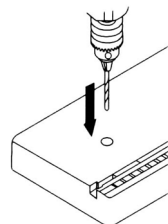

## Preparation

### Caution

- Always be sure to ground before connecting the power supply. Never ground to a gas pipe, as there is the danger of a fire or an explosion.
- Always be sure that the ON/OFF switch is turned off before plugging into the power cord. It is very dangerous if plug in the power cord while the switch is ON.

- 5** Loosen the grounding screw (at terminal) on the base and connect the grounding wire. Securely connect to the other end of the grounding wire to the grounding terminal at the power supply. If the power supply has no grounding terminal, ask a qualified electrician to install a proper grounding by using a separate grounding rod, and then connect the grounding wire securely. Plug in the power cord to a properly-rated power supply.



- 6** Plug in the power cord to a properly-rated wall outlet.

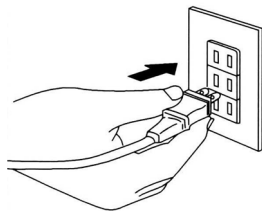

## Operation

### Caution

- Be sure that the chuck wrench is detached before power on. Otherwise, it could fly from the spinning chuck causing injury to personnel.
- Do not wear gloves while operating since they could get caught in the moving parts.
- Wear safety glasses to protect your eyes against cut fragments.
- Do not pull the vertical lift handle hastily. Do not squeeze it excessively. Such handling is not only inefficient but also applies an excessive load on the desk drill, causing a malfunction, a breakdown or a deformation of the drill bit.

- 1** Be sure that the chuck wrench is detached. Turn the power switch on. The drill will start to spin.

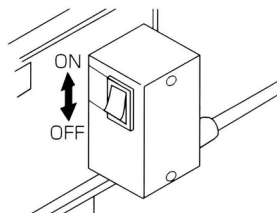

## Operation

- 2** Lower the vertical lift handle gradually to start drilling.  
Pressing with excessive force may impede the drill's spinning.  
Always operate with cautious allowances.

- 3** Gently raise the vertical lift handle after drilling is completed.

 **Caution**

Gently raise the vertical lift handle while holding it with your hand. Otherwise, the spring could cause the handle to return violently.

- 4** Turn the power switch off and disconnect the power plug after the work is finished.

 **Caution**

The drill continues spinning when the power switch is not turned off or the plug is not disconnected. Keep the human body and other objects away from the spinning part to avoid getting caught.

- 5** After the work is finished, using the chuck wrench, and being sure that the power plug is disconnected, remove the drill bit.  
Clean the scraps and dust from the base.  
Frequently check to ensure there are no loose parts and no malfunctions of the desk drill. If a problem is found, ask your nearest HOZAN dealer to carry out any necessary repairs.

# Operation

## Adjusting the operation speed

The operating speed of the drill can be adjusted to one of three speed ranges. Select the appropriate speed for the size of drill bit to be used.

At the time of shipment from the factory, the drill is set to the low speed setting(2100 rpm).

### Determining the speed (for reference)

Drill bit	Belt position
6.0-3.0mm	Top (low speed);2100 rpm
3.0-1.5mm	Middle (Medium speed);4500 rpm
1.5-0.5mm	Bottom (High speed);6200 rpm

rpm=revolutions per minute

Turn the grip bolt counter clockwise. The belt cover can then be removed. Attach the belt in one of the three possible settings (top, middle, bottom) using the table of speeds given above as a guide. Be sure to replace the belt cover after completing the adjustment.

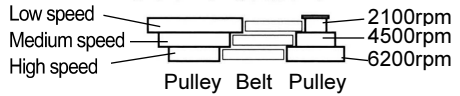
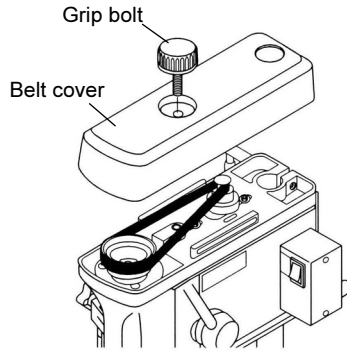

Never attach the belt at any other than horizontally.

## Depth adjustment mechanism

The drilling depth can be adjusted to the maximum of 30 mm.

Adjust the height of the main unit so that the top of the drill bit comes in contact with the workpiece.

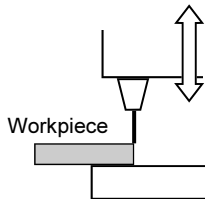

Turn the knob to move the stopper of the depth adjustment mechanism in order to align it with the desired drilling depth on the scale.

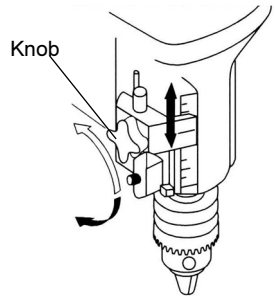

## Using the slide-guide

Install the slide-guide on the base.

Once the position has been determined, tighten with the hex wrench provided.

You can drill holes in line by using the slide-guide. Also it prevents workpieces from rotating with the drill.

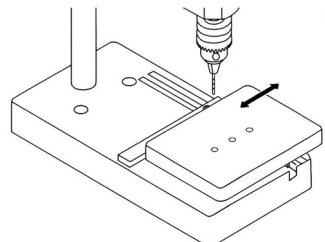
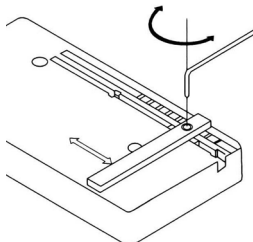

## Operation

### Adjusting the belt tension

The tension of the belt is adjusted when shipping. The long time use requires readjustment of the belt tension.

Use a wrench to slightly loosen the two motor mounting nuts shown in the illustration, and then move the motor pulley forward or back to adjust the tension.

Place the belt at the top of the pulley when carrying out this adjustment.

Once the pulley position has been determined, securely tighten the two motor mounting nuts. Be sure to replace the belt cover after adjustment is completed.

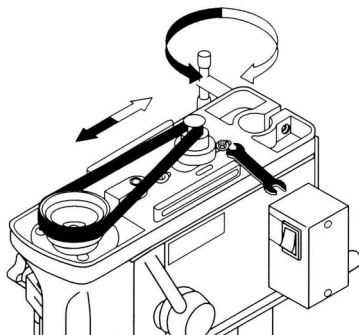

#### Caution

- If the belt tension is too tight, the revolution of the motor will drop and will shorten the belt and motor life.
- If the belt tension is too loose, belt play causes the slippage of belt.

## Options

### K-21-1 COLLET CHUCK

The precision of the axial play drops when using a conventional drill chuck. (Drops to 0.07mm when use a conventional chuck.) The collet chuck is capable to keep the axial play as the K-21 does.

- Applicable drills: 1.0/1.5/2.0/2.4/3.0mm dia. (special collets exist for each)
- Axial play when attached: 0.04mm

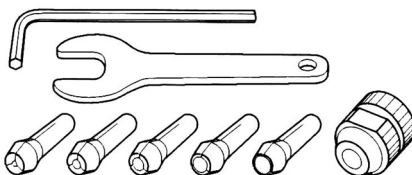

### How to install the COLLET CHUCK

Using the chuck wrench, make the chuck quite open.

While locking the main shaft using the hex key (provided with the K-21) and such, turn the entire chuck counterclockwise (looking from bottom) holding with a palm securely to remove it.

Thread the collet cover with the desired sized collet. Insert the drill bit into the collet. Then, secure the collet cover with the wrench provided.

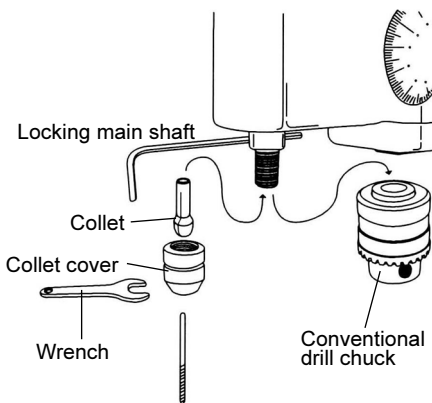

## Options

### K-50 XY-Table

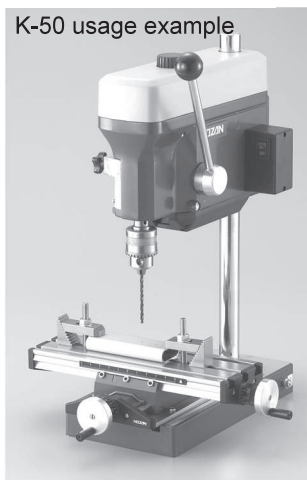

Suitable for precious drilling against PCBs and such.  
Holes at regular intervals can be gotten.

### K-24 Vise



Supports the object.  
Mountable on the K-21 parallel guide.

### K-5 Drill bit set (7 pieces)

0.8/1.0/1.5/2.0/2.5/3.0/3.2mm

### K-493 Drill bit set (13 pieces)

1.5/2.0/2.5/3.0/3.2/3.5/4.0/4.5/4.8/5.0/5.5/6.0/6.5mm

### K-494 Drill bit set (19 pieces)

1.0/1.5/2.0/2.5/3.0/3.5/4.0/4.5/5.0/5.5/6.0/7.0/7.5/8.0/8.5/9.0/9.5/10.0mm.

### K-495 Drill bit set (5 pieces)

0.5/0.6/0.8/1.0/1.2mm

\* The chuck clamping capacity is 0.8 to 6.0mm, so drills other than this capacity can not be attached.

**HOZAN TOOL INDUSTRIAL CO.,LTD.**

1-2-12 Saiwaicho, Naniwa-ku, Osaka 556-0021, Japan  
<https://www.hozan.co.jp/E/> E-mail : [th@hozan.co.jp](mailto:th@hozan.co.jp)